

INDEX	PART#	DESCRIPTION	QTY
1	9000-0048	SCR HHC 1/2-13*2.0L GR 5 STL ZN PLD"	12
2	9001-1006	NUT 1/2-13 NYLOK HEX STL ZN PLD	12
3	9002-0001	WSHR 1/2" FLAT SAE STL ZN PLD	24
4	9004-0032	RIVET .125" .03-.12" POP SST DOME HD	4
5	9070-1007	SPRING CLIP, PANDROL	8
6	9070-1008	SPRING CLIP INSULATOR, PANDROL	8
7	14787-01	RAIL PAD, INSUL PANDROL 6.0" BASERAIL	2
8	14847-02	INSULATOR, TIEPLATE, 10P NO HOLES	2
9	15789	TIEPLATE ASSY 10P 6"BASE 1:40 CANT	2
10	16258	TAG, MODEL ID, PRE-SERIALIZE	1
11	16259	LABEL, MODEL ID for SERIAL TAGS	1
12	18152-01	ADPTR/ENDPLATE, TIE > 10" FLEX, PAINTED	2
13	18152-POLYETHYLENE	PLASTIC SHEET, POLYETHELENE	2
14	18156	GSKT, TIEDUCT END PLATE	2
15	18157	GUARD, ADPTR/ENDPLATE, TIE > 10" FLEX, PAINTED	2
16	18196	DUCT, TIE 10P ASSY EXT W/O PLATES 111"L, PAINTED	1

TITLE TIEDUCT ASSY, 10 X 10 PANDROL NO HOLES, 6.0 BASE RAIL	DRAWING NUMBER 18197	REV. F SHT. 1/4
---	-------------------------	--------------------------

**TIEDUCT NO HOLES  
PANDROL FASTENERS  
6.0" BASE RAIL  
1:40 CANT  
18197-01  
GENERIC**

**NOTE:**

1. APPLY ANTI-SEIZE 9014-0042 TO ALL 3/8-16 BOLTS
2. PACKAGE 2 RAIL PADS, 4 CLIPS, 4 CLIP INSULATORS AND TIEDUCT INSTALLATION INSTRUCTIONS 11387 UNDER SHIPPING COVER, 15820-02.

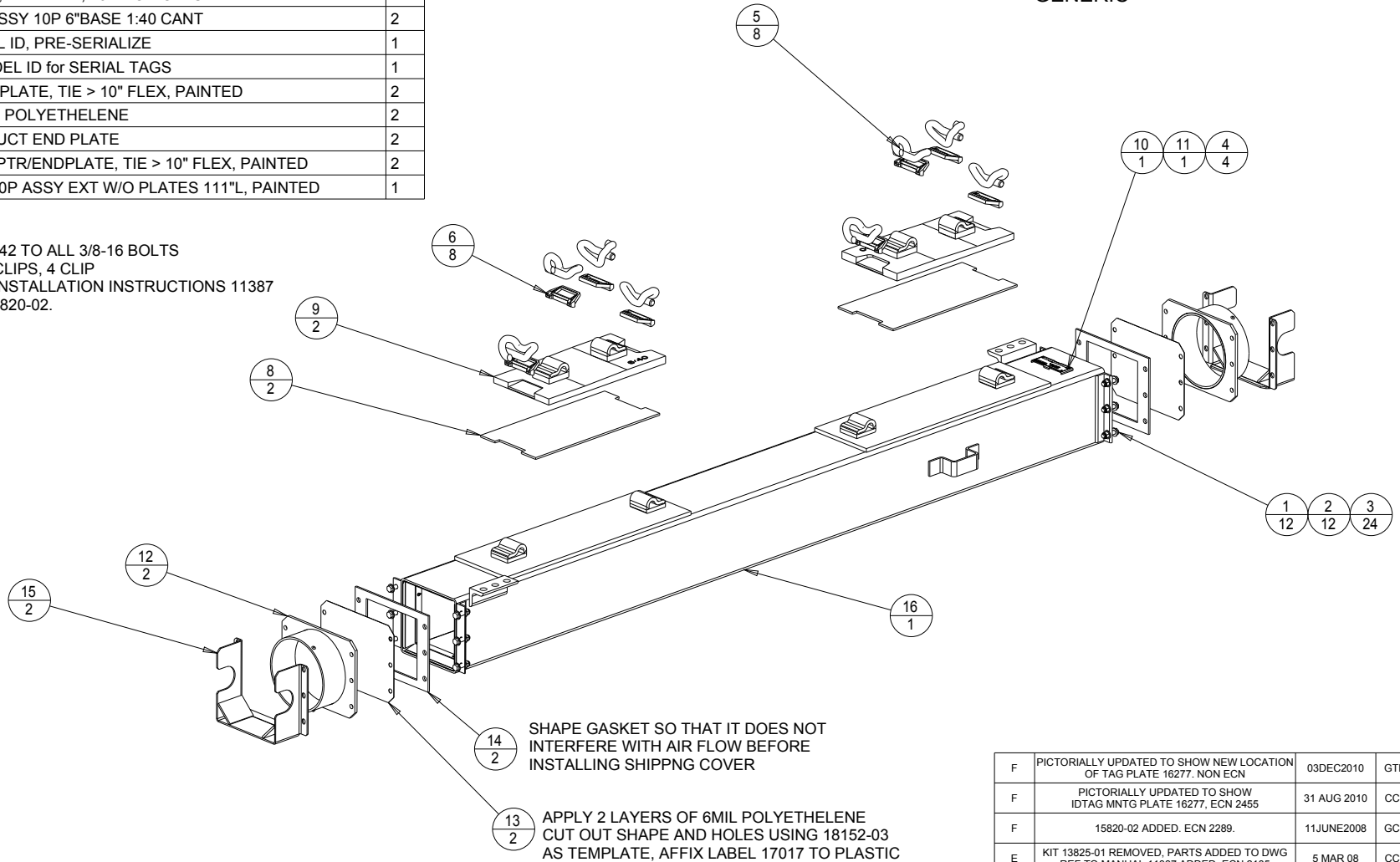

F	PICTORIALLY UPDATED TO SHOW NEW LOCATION OF TAG PLATE 16277, NON ECN	03DEC2010	GTM
F	PICTORIALLY UPDATED TO SHOW IDTAG MNTG PLATE 16277, ECN 2455	31 AUG 2010	CCB
F	15820-02 ADDED, ECN 2289.	11JUNE2008	GCH
E	KIT 13825-01 REMOVED, PARTS ADDED TO DWG REF TO MANUAL 11387 ADDED, ECN 2185	5 MAR 08	CCB
D	16258 & 16259 WAS 16256-03 ECN 1990	6 JUNE 05	AVG
C	9001-0022 AND 9002-1002 REPLACED BY 9001-1006, ECN 1820	17 MAY 04	AVG
B	SHIP COVER 18152 REPLACED BY 6 MIL POLYETHELENE PLASTIC SHEET, ECN 1632	3 DEC 02	CCB
LTR	DESCRIPTION	DATE	CHKD

MATERIAL	SEE INDIVIDUAL PART DRAWINGS
----------	------------------------------

SCALE	UNLESS OTHERWISE SPECIFIED DIMENSIONS ARE IN INCHES	XX ± 0.03 XXX ± 0.01	ANGLES ± 0.5 ° OTHER _____
AS SHOWN			

HOVEY INDUSTRIES (2005) INC.			
DWN	DATE DWN	CHKD	DATE
SFL	04 JUNE 02		

DWG SIZE	A1
LTR	DESCRIPTION
DATE	CHKD