

TIEDUCT WITH NOZZLES  
 SWITCH POINTS  
 SAFELOK FASTENERS  
 5.5" BASE RAIL  
 ZERO CANT.

TITLE TIEDUCT ASSY, NOZZLE, 10 X 10 SAFELOK, 5.5" BASE RAIL		DRAWING NUMBER 18193	REV. F SHT. 1/1
---	--	-------------------------	--------------------------

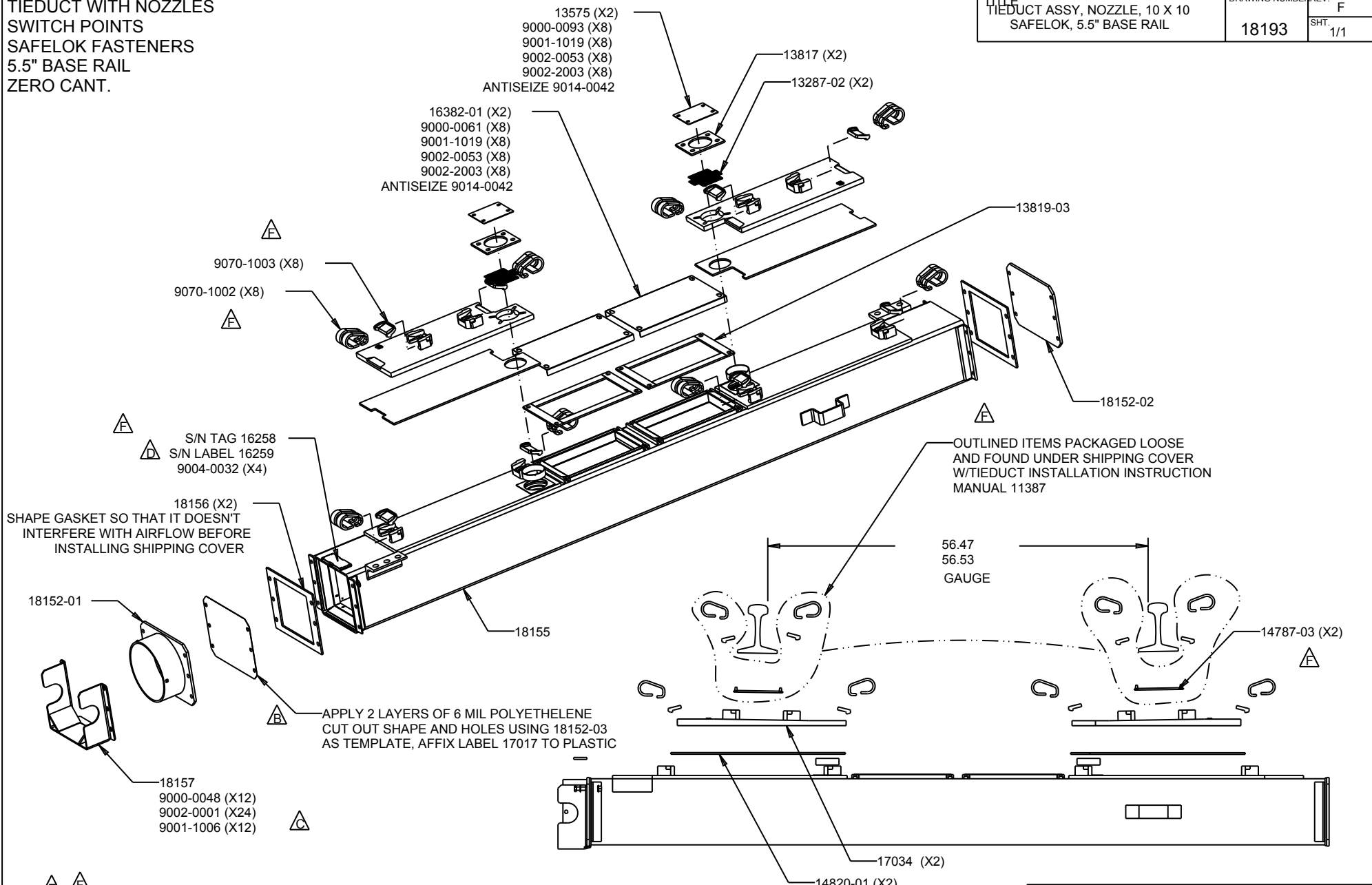

SCALE 0.050

MATERIAL	SEE INDIVIDUAL PART DRAWINGS
----------	------------------------------

SCALE	AS SHOWN	UNLESS OTHERWISE SPECIFIED DIMENSIONS ARE IN INCHES	XX ± 0.03 XXX ± 0.01	ANGLES ± 0.5 ° OTHER _____
-------	----------	---	-------------------------	-------------------------------

HOVEY INDUSTRIES (2005) INC.			
DWN	DATE DWN	CHKD	DATE
SFL	03 JUNE 02		

DWG SIZE	A1		
LTR	DESCRIPTION	DATE	CHKD

F	PICTORIALLY UPDATED TO SHOW IDTAG MNTG PLATE 16277, ECN 2455	31 AUG 2010	CCB
F	KIT 13824-02 REMOVED, PARTS ADDED TO DWG REF TO MANUAL 11387 ADDED, NOTE 1 REMD, ECN 2185	5 MAR 08	CCB
E	APPLY RTV NOTE REMOVED, ECN 2184	5 MAR 07	CCB