

TIEDUCT WITH NOZZLES
 SWITCH POINTS
 SAFELOK FASTENERS
 6" BASE RAIL
 1:60 CANT.

TITLE TIEDUCT ASSY, NOZZLE 10X10 SAFELOK, 6" BASE RAIL, 1:60 CANT	DRAWING NUMBER 18163	REV. F SHT. 1/1
---	-------------------------	--------------------------

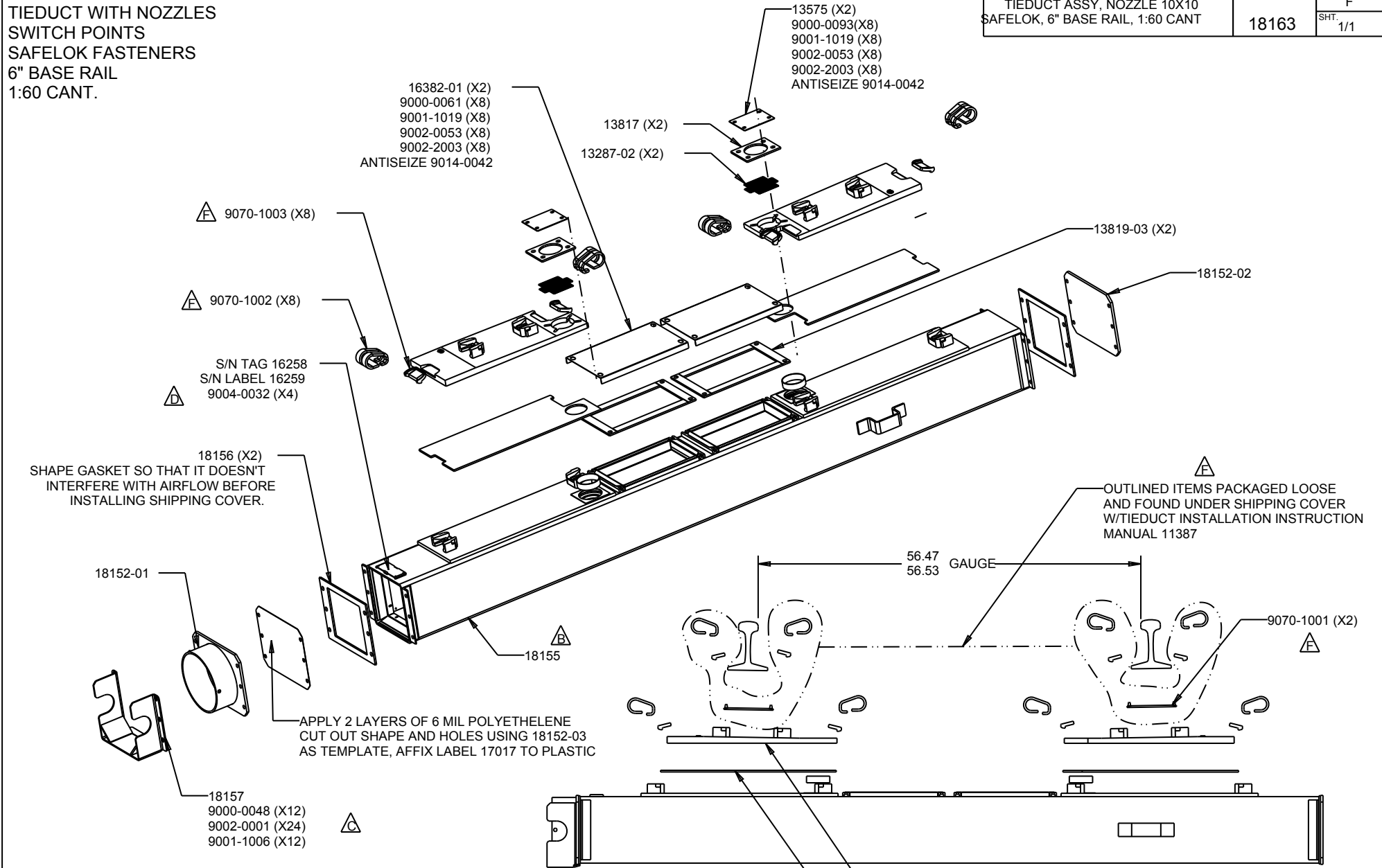

MATERIAL SEE INDIVIDUAL PART DRAWINGS	SCALE AS SHOWN	UNLESS OTHERWISE SPECIFIED DIMENSIONS ARE IN INCHES	XX ± 0.03 XXX ± 0.01	ANGLES ± 0.5 ° OTHER _____	HOVEY INDUSTRIES (2005) INC.				DWG SIZE A1	<table border="1"> <tr> <td>F</td> <td>PICTORIALLY UPDATED TO SHOW IDTAG MNTG PLATE 16277, ECN 2455</td> <td>11 AUG 2010</td> <td>CCB</td> </tr> <tr> <td>F</td> <td>KIT 13824 REMOVED, PARTS ADDED TO DWG REF TO MANUAL 11387 ADDED, NOTE 1 REMD ECN 2185</td> <td>28 FEB 08</td> <td>CCB</td> </tr> <tr> <td>E</td> <td>APPLY RTV NOTE REMOVED, ECN 2184</td> <td>5 MAR 2007</td> <td>CCB</td> </tr> <tr> <td>LTR</td> <td>DESCRIPTION</td> <td>DATE</td> <td>CHKD</td> </tr> </table>			F	PICTORIALLY UPDATED TO SHOW IDTAG MNTG PLATE 16277, ECN 2455	11 AUG 2010	CCB	F	KIT 13824 REMOVED, PARTS ADDED TO DWG REF TO MANUAL 11387 ADDED, NOTE 1 REMD ECN 2185	28 FEB 08	CCB	E	APPLY RTV NOTE REMOVED, ECN 2184	5 MAR 2007	CCB	LTR	DESCRIPTION	DATE	CHKD
					F	PICTORIALLY UPDATED TO SHOW IDTAG MNTG PLATE 16277, ECN 2455	11 AUG 2010	CCB																				
F	KIT 13824 REMOVED, PARTS ADDED TO DWG REF TO MANUAL 11387 ADDED, NOTE 1 REMD ECN 2185	28 FEB 08	CCB																									
E	APPLY RTV NOTE REMOVED, ECN 2184	5 MAR 2007	CCB																									
LTR	DESCRIPTION	DATE	CHKD																									
DWN SFL	DATE DWN 20 MAR 02	CHKD	DATE																									