

PACKAGED LOOSE	
12241	INSLT KIT
13341-03	THERMO INSLT KIT
16738	GSKT KIT
16740	DOC PKG

TITLE	HF 400, 240V CN W/BOLT-ON LEGS	DRAWING NUMBER	18005	REV.	K
				SHT	2/4

QA CHECK LIST
18603

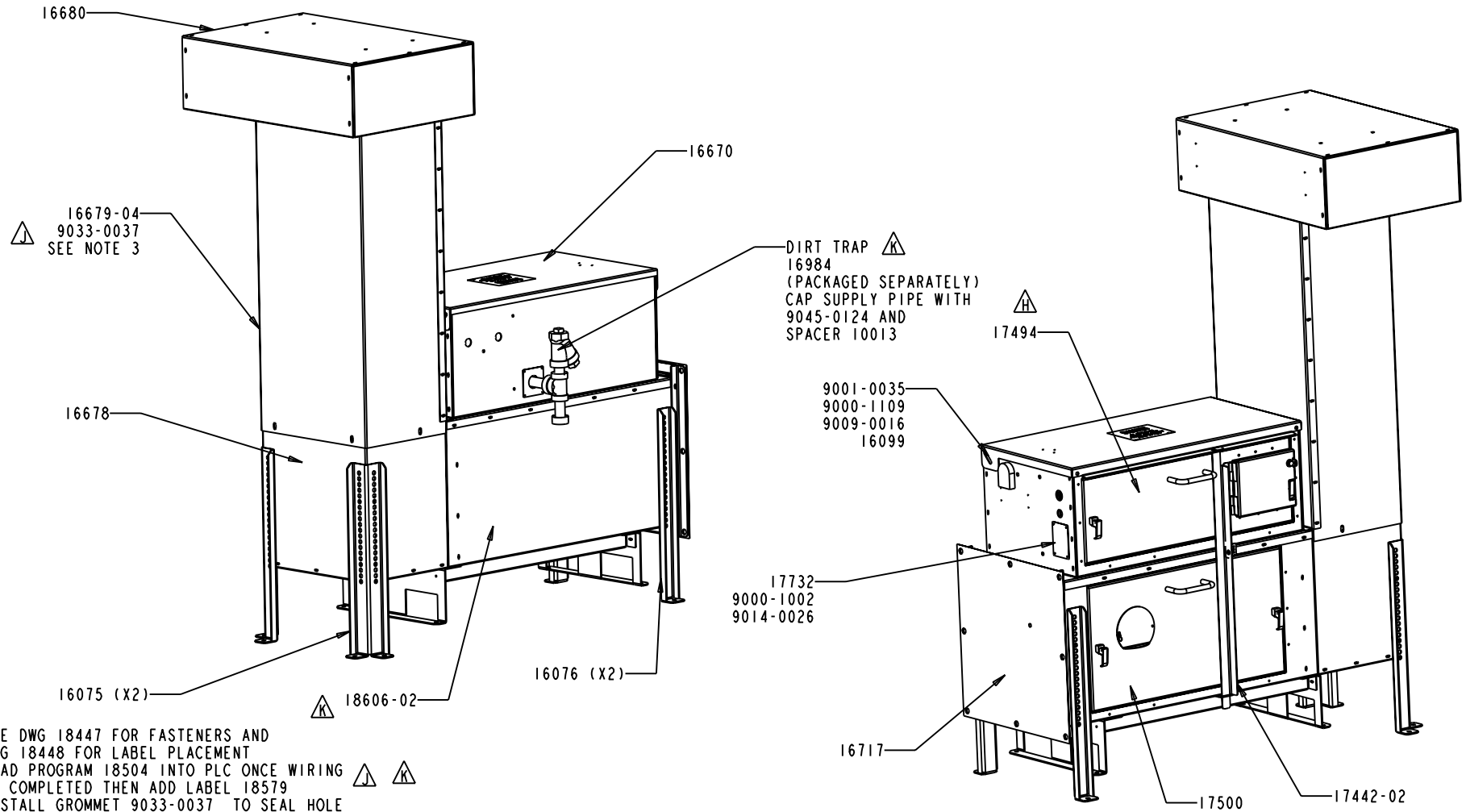

- NOTE:
1. SEE DWG 18447 FOR FASTENERS AND DWG 18448 FOR LABEL PLACEMENT
 2. LOAD PROGRAM 18504 INTO PLC ONCE WIRING IS COMPLETED THEN ADD LABEL 18579
 3. INSTALL GROMMET 9033-0037 TO SEAL HOLE AT BOTTOM OF THE AIR INTAKE EXTENSION

SCALE 0.060

18005-02
HIGH INTAKE W/O EMS

K	PROGRAM 18504 WAS 17688, LABEL 18579 WAS 17733, 18602-02 WAS 16700-02, ECN 1944	21 MAR 05	AVG
J	HDW REFERENCE MOVED TO DWG 18447 LABELS REFERENCES MOVED TO DWG 18448	24 AUG 04	AVG
J	GROMMET 9033-0037 AND NOTE 3&4 ADDED ECN 1855	6 AUG 04	AVG
H	NOTE ADDED, 17494 WAS 17499 9045-0124 WAS 9009-0017, ECN 1802	3 MAY 04	AVG
AI	DESCRIPTION	DATE	CHKD

MATERIAL
SEE INDIVIDUAL PARTS DRAWING

SCALE
AS SHOWN

UNLESS OTHERWISE SPECIFIED
DIMENSIONS ARE IN INCHES

XX ± 0.03
XXX ± 0.01

ANGLES ± 0.5°
OTHER -----

HOVEY INDUSTRIES 2005 INC

DWN MEP DATE DWN 8 FEB 01

CHKD DATE

DWG SIZE
AI

LTR