

PACKAGED LOOSE	
PART	DESCRIPTION
12241	KIT HDW INSTALLATION
10804	KIT CONVERT TO NG
13341-03	KIT INSL THERMOS
13393	KIT GSKT
18596	DOC PKG
9040-0017	FLAME SAFETY RELAY

TITLE	HF 900, 575V CN W/BOLT-ON LEGS	DRAWING NUMBER	18004	REV.	G
				SHT.	3/4

16441-01
C/W CABLE ASSY



16442-03
C/W CABLE ASSY

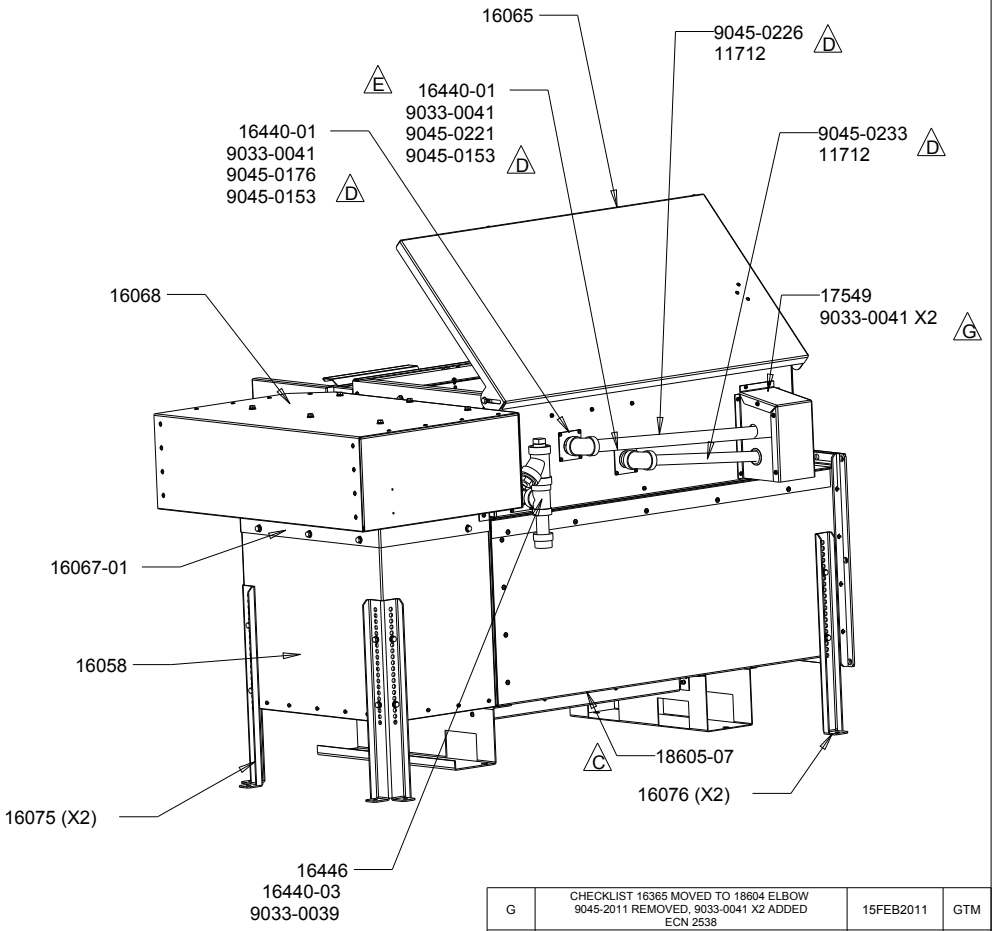
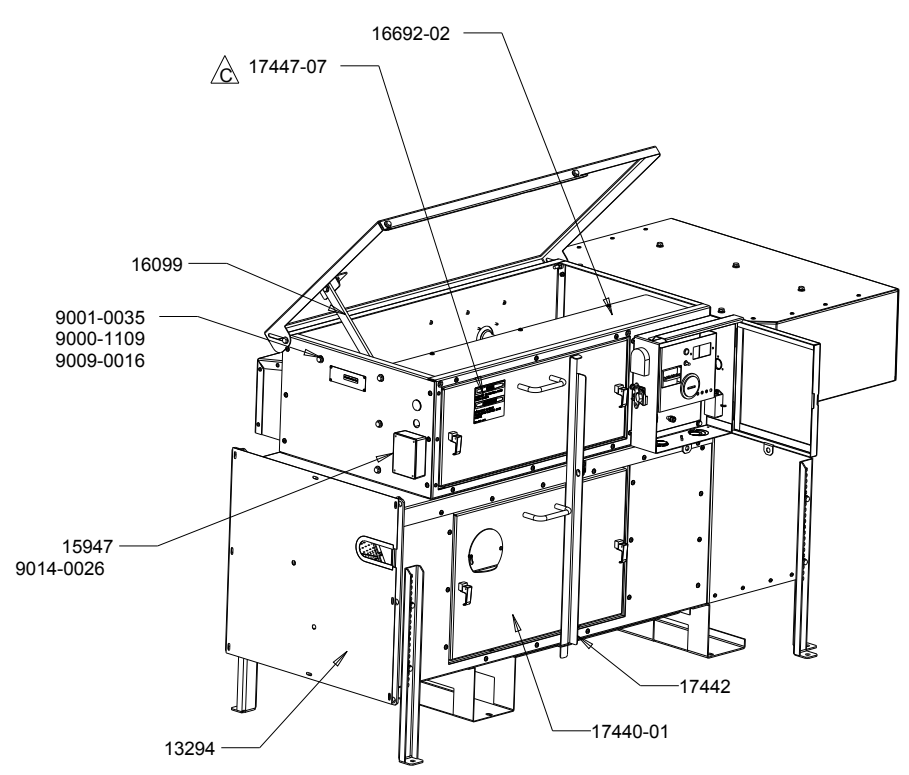

- NOTE:
- SEE DWG 18449 FOR FASTENERS AND DWG 18450 FOR LABEL PLACEMENT
 - TEST ACCORDING TO TEST SHEET 18604
 - LOAD PROGRAM 18504 INTO LOGO PLC ONCE WIRING IS COMPLETED THEN ADD LABEL 18579

SCALE 0.050

18004-03 LOW INTAKE
W/EMS

REV	DESCRIPTION	DATE	CHKD
G	CHECKLIST 16365 MOVED TO 18604 ELBOW 9045-2011 REMOVED, 9033-0041 X2 ADDED ECN 2538	15FEB2011	GTM
F	10804 WAS 12826, ECN 2126	7 JUL 06	AVG
E	9045-0221 WAS 0120 9045-0211 REMOVED, ECN 1917	29 NOV 05	CCB
D	PROGRAM 18504 WAS 17688, LABEL 18579 WAS 17733M 18605-07 WAS 16444-07 18604 WAS 16364, 18596 WAS 16360, 9045 -0211 WAS 9045-0109, 9040-0017, 16365 ADDED, 9045-0201 WAS 24" PIPE, 9045-0054 WAS 17" PIPE, 9045-0153 ADDED, ECN 1944	21 MAR 05	AVG

MATERIAL	SEE INDIVIDUAL PARTS DRAWING
----------	------------------------------

SCALE	AS SHOWN	UNLESS OTHERWISE SPECIFIED DIMENSIONS ARE IN INCHES	XX ± 0.03 XXX ± 0.01	ANGLES ± 0.5 ° OTHER _____
-------	----------	--	-------------------------	-------------------------------

HOVEY INDUSTRIES 2005 INC				DWG SIZE
DWN	MEP	DATE DWN	24 JAN 01	CHKD
			DATE	A1

LTR	DESCRIPTION	DATE	CHKD
-----	-------------	------	------