

PACKAGED LOOSE	
PART	DESCRIPTION
12241	KIT HDW INSTALLATION
10804	KIT CONVERT TO NG
13341-03	KIT INSL THERMOS
13393	KIT GSKT
18596	DOC PKG
9040-0017	FLAME SAFETY RELAY

TITLE	HF 900, 575V CN W/BOLT-ON LEGS	DRAWING NUMBER	REV.
		18004	G
			SHT. 2/4

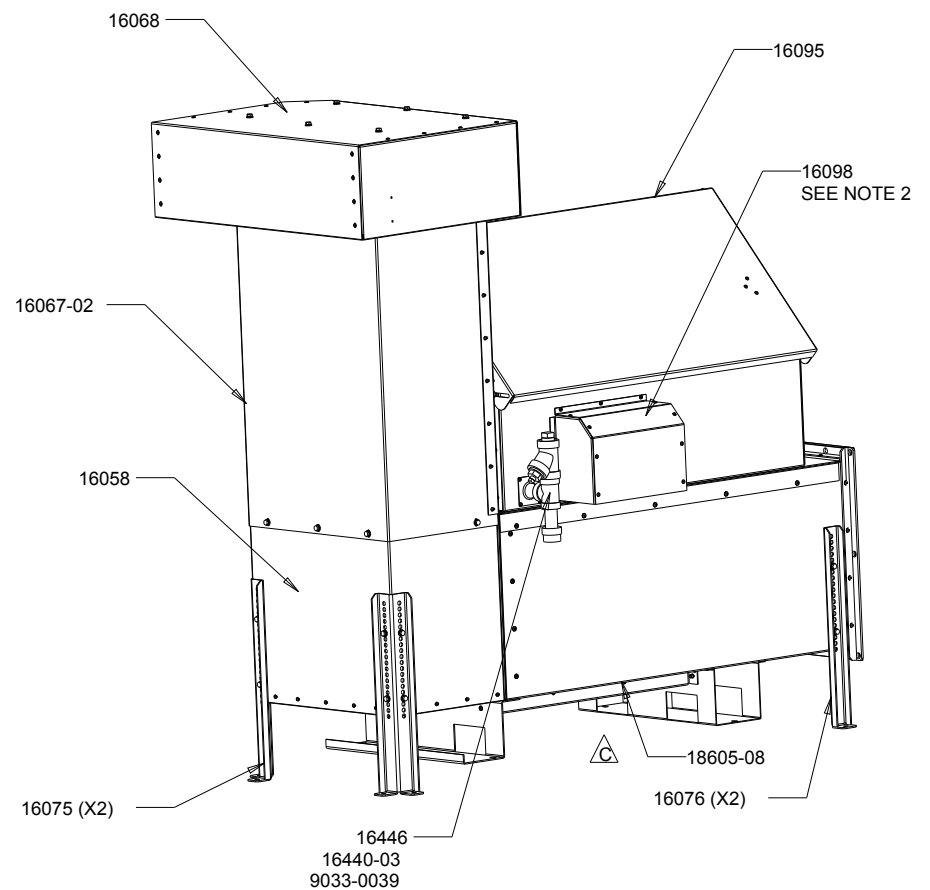
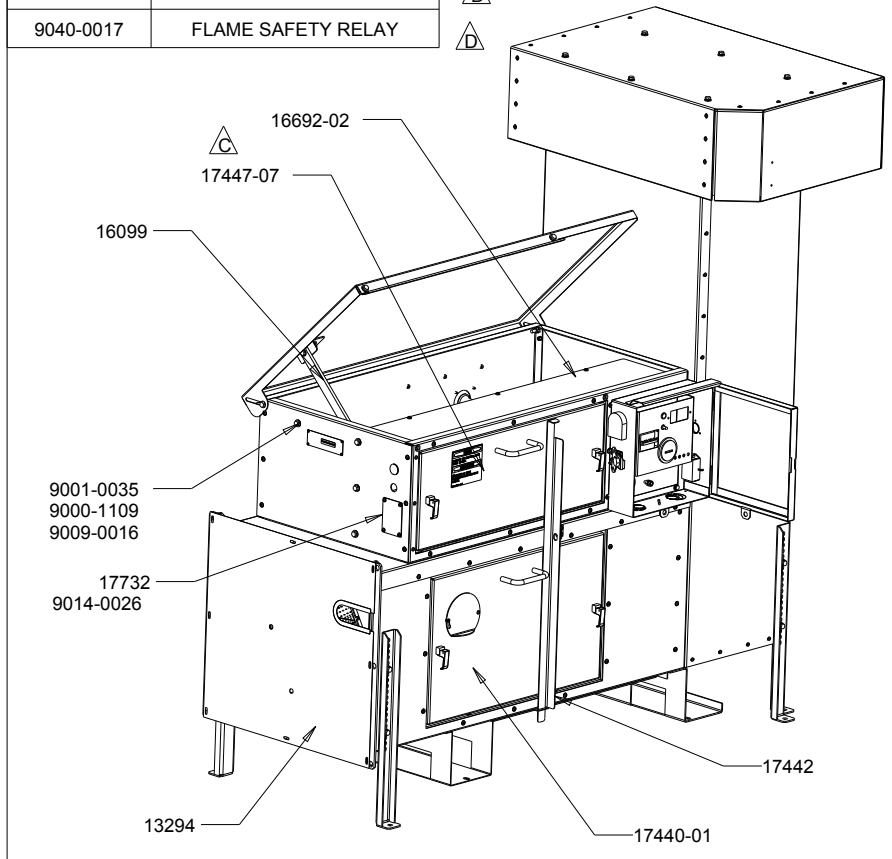

- NOTE:
- SEE DWG 18449 FOR FASTENERS AND DWG 18450 FOR LABEL PLACEMENT
 - 16440-01 (X2), 9033-0041 (X2), 11712 (X2), 9045-0176 & 9045-0221 LOCATED BEHIND THIS PANEL
 - TEST ACCORDING TO TEST SHEET 18604
 - LOAD PROGRAM 18504 INTO LOGO PLC ONCE WIRING IS COMPLETED THEN ADD LABEL 18579

SCALE 0.050

18004-02 HIGH INTAKE
W/O EMS

MATERIAL	SEE INDIVIDUAL PARTS DRAWING
----------	------------------------------

SCALE	UNLESS OTHERWISE SPECIFIED DIMENSIONS ARE IN INCHES	XX ± 0.03 XXX ± 0.01	ANGLES ± 0.5 ° OTHER _____
AS SHOWN			

HOVEY INDUSTRIES 2005 INC			
DWN	DATE DWN	CHKD	DATE
AVG	14 MAY 04		

DWG SIZE	A1		
LTR	DESCRIPTION	DATE	CHKD

G	CHECKLIST 16365 MOVED TO 18604 ELBOW 9045-2011 REMOVED, SEE SHT. 3.4 FOR CHANGES ECN 2538	15FEB2011	GTM
F	10804 WAS 12826, ECN 2126	7 JUL 06	AVG
E	9045-0221 WAS 0120 9045-0211 REMOVED, ECN 1917	29 NOV 05	CCB
D	PROGRAM 18504 WAS 17688, LABEL 18579 WAS 17733M 18605-08 WAS 16444-08 18604 WAS 16364, 18596 WAS 16360, 9040-0017 AND 16365 ADDED, 9045-0211 WAS 9045-0109, ECN 1944D	21 MAR 05	AVG