

PACKAGED LOOSE	
PART	DESCRIPTION
12241	KIT HDW INSTALLATION
10804	KIT CONVERT TO NG
13341-03	KIT INSL THERMOS
13393	KIT GSKT
18596	DOC PKG
9040-0017	FLAME SAFETY RELAY

TITLE	HF 900, 240V CN W/BOLT-ON LEGS	DRAWING NUMBER	REV.
		18001	H SHT. 4/4

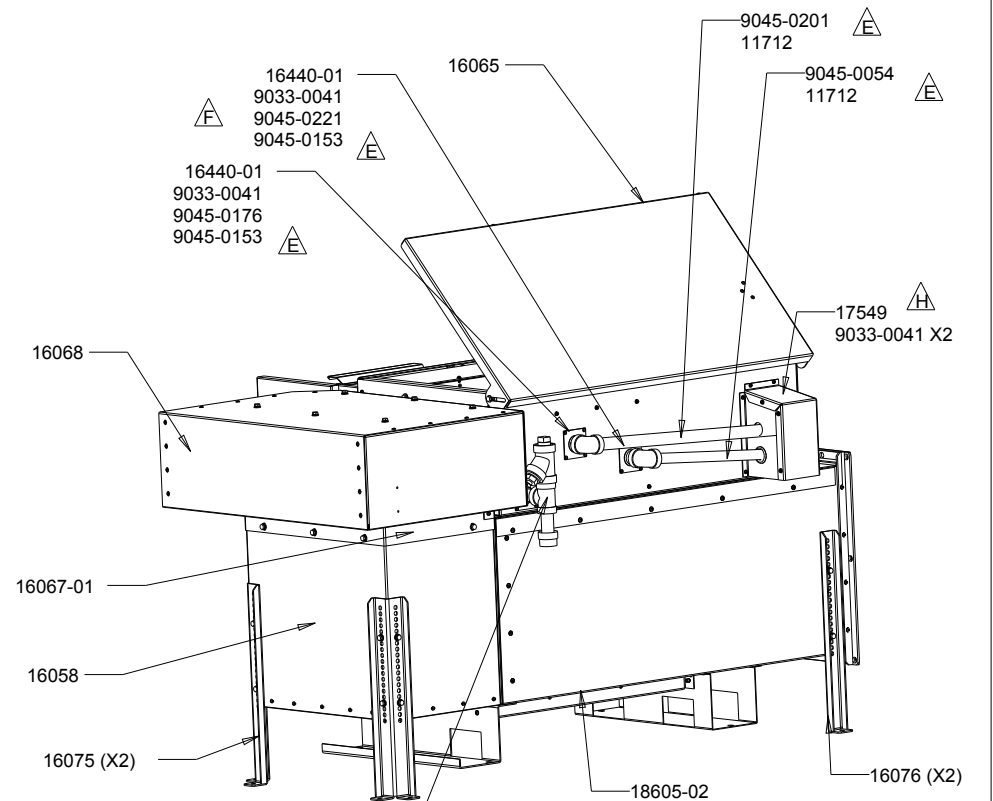
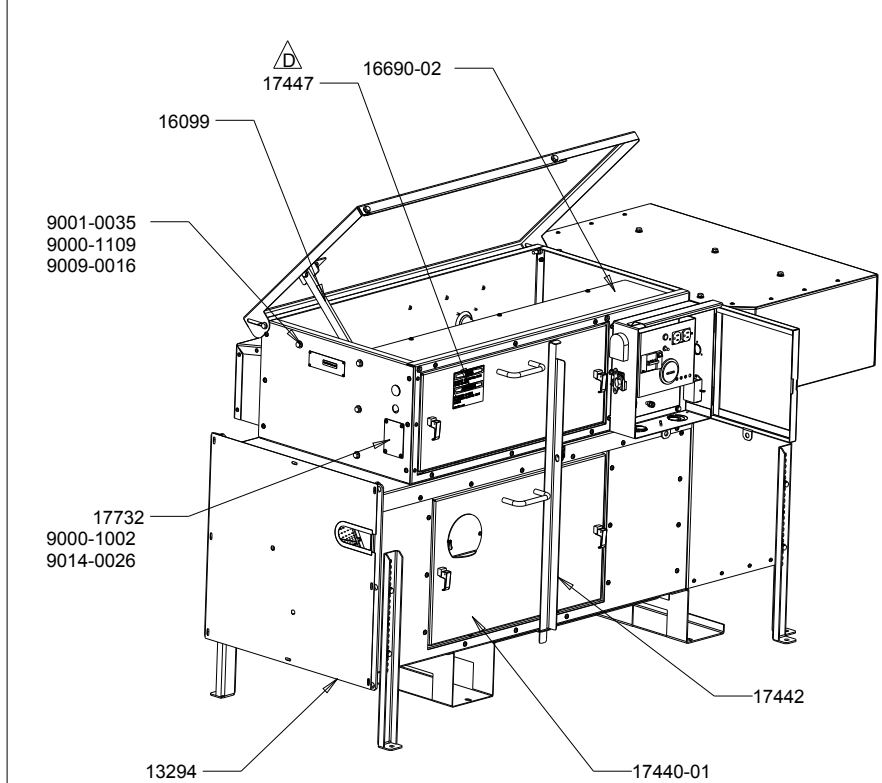

NOTE:
 1. SEE DWG 18449 FOR FASTENERS
 AND DWG 18450 FOR LABEL PLACEMENT
 2. TEST ACCORDING TO TEST SHEET 18604
 3. LOAD PROGRAM 18504 INTO LOGO PLC ONCE
 WIRING IS COMPLETED THEN ADD LABEL 18579

SCALE 0.050

18001-04 LOW INTAKE
W/O EMS

REV	DESCRIPTION	DATE	CHKD
H	CHECKLIST 16365 MOVED TO 18604 9033-0041 X2 ADDED, ECN 2538	15FEB2011	GTM
G	10804 WAS 12826, ECN 2126	7 JUL 06	AVG
F	9045-0221 WAS 0120 9045-0211 REMOVED, ECN 1917	14 NOV 05	AVG
E	PROGRAM 18504 WAS 17688, LABEL 18579 WAS 17733, 18605-02 WAS 16444-02, 18604 WAS 16364 18596 WAS 16360, 9040-117, 16365 AND 9045-0153 ADDED, 9033-0221 WAS 9045-0108, 9045-0201 WAS 24" PIPE, 9045-0054 WAS 17" PIPE, ECN 1944D	23 MAR 05	AVG
D	HDW REFERENCE MOVED TO DWG 18449 LABELS REFERENCES MOVED TO DWG 18450	27 AUG 04	AVG
LTR	DESCRIPTION	DATE	CHKD

MATERIAL	SEE INDIVIDUAL PARTS DRAWING
----------	------------------------------

SCALE	AS SHOWN	UNLESS OTHERWISE SPECIFIED DIMENSIONS ARE IN INCHES	XX ± 0.03 XXX ± 0.01	ANGLES ± 0.5 ° OTHER _____
-------	----------	--	-------------------------	-------------------------------

HOVEY INDUSTRIES 2005 INC			
DWN	DATE DWN	CHKD	DATE

DWG SIZE	A1
----------	----