

INDEX	PART#	DESCRIPTION	QTY
1	11220-02	DFTR, 8"W FOR WOOD TIE W/ANTI SLIP	2
2	11232-02	DUCT, TRACK 8*4*48" FLGD/CAP	2
3	14295-02	DFTR, 18"W FOR WOOD TIE W/ANTI SLIP	2
4	15157	BRKT, TD 2.19"H ADJ 8"TD SH	2
5	17173-01_LEFT	NOZ ASSY, SH POINT END, RAIL MTG TDUCT	1
6	17173-01_RIGHT	NOZ ASSY, SH POINT END, RAIL MTG TDUCT	1
7	17739	TRACK DUCT SUPPORT, GAUGE PLATE	2
8	17899-01	ELBOW, TD 8*4" QDISC FLTG TIE	2

TITLE TRACKDUCT SYS, SH TIE>8*4** 4' W/TIE	DRAWING NUMBER	REV.
	17843	F SHT. 1/1

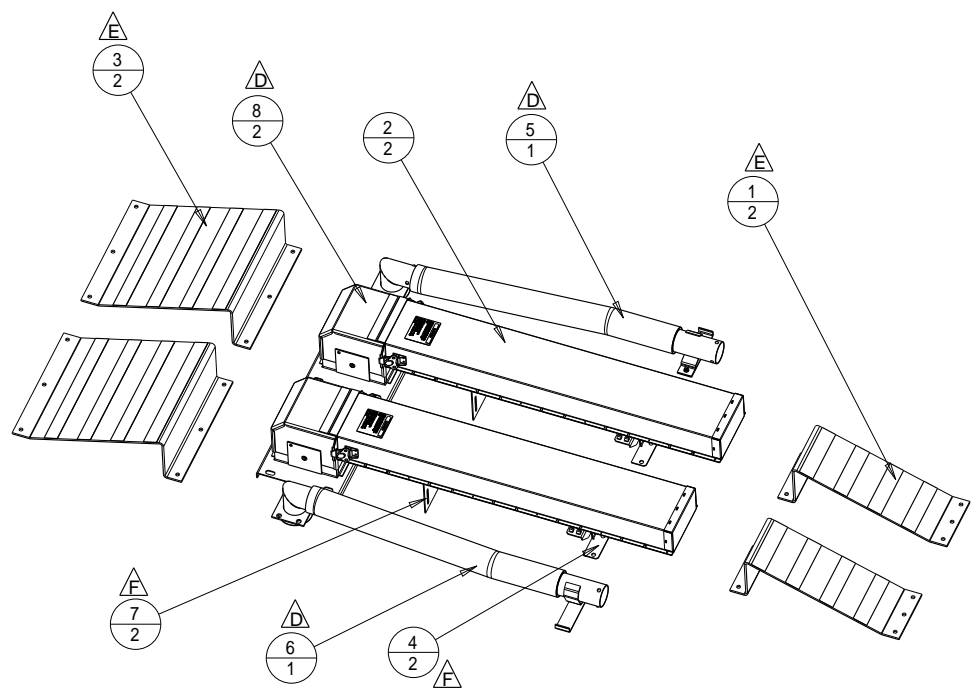

DEFLECTOR HDW KIT
P/N 16022

WOOD-TIE CONFIGURATION

SCALE 0.040

MATERIAL SEE INDIVIDUAL PART DRAWINGS

SCALE AS SHOWN
UNLESS OTHERWISE SPECIFIED DIMENSIONS ARE IN INCHES
XX ± 0.03
XXX ± 0.01
ANGLES ± 0.5 °
OTHER _____

HOVEY INDUSTRIES 2005 INC
DWN GTM DATE DWN 25NOV2010
CHKD DATE

DWG SIZE A1

F	RE-DRAWN IN PRO-E, 17739 X2 & 15157 X2 WAS 15152 X4, ECN 2405	25NOV2010	GTM
E	ANTI SLIP VARIANT DEFLECTORS -02 WAERE -01, ECN 1437	15JAN2002	CCB
D	17899 WAS 13818, 17173 WAS 10090 & 13816 ECN 1363	04OCT2001	MEP
REV	DESCRIPTION	DATE	CHKD