

16356-01 W/EMS
16356-02 W/O EMS

- NOTE:
1. TEST ACCORDING TO TEST SHEET 18604
 2. LOAD PROGRAM 18504 INTO LOGO PLC ONCE WIRING IS COMPLETED THEN ADD LABEL 18579 USE SCHEMATIC 15942
 3. TEST ACCORDING TO TEST SHEET 18604
 4. WIRE ALL COMPONENTS USING BX CABLE 9007-0034 AND STRGT CONN 9019-0012 AND 90 DEG CONN 9019-0017 AS REQ'D.
 5. PERFORM FINAL INSPECTION AS PER 16365.

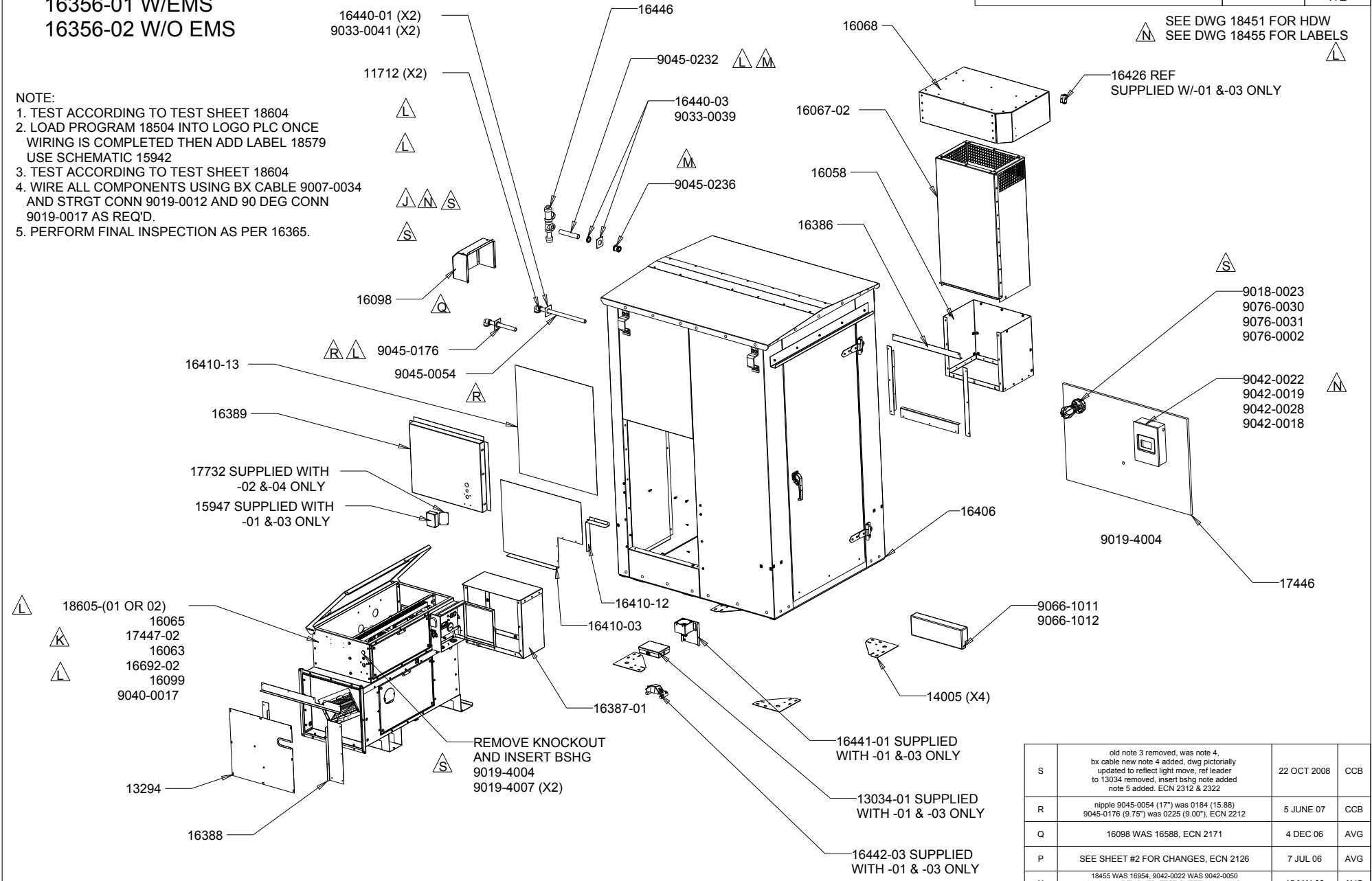

S	old note 3 removed, was note 4, bx cable new note 4 added, dwg pictorially updated to reflect light move, ref leader to 13034 removed, insert bshg note added note 5 added. ECN 2312 & 2322	22 OCT 2008	CCB
R	nipple 9045-0054 (17") was 0184 (15.88) 9045-0176 (9.75") was 0225 (9.00"), ECN 2212	5 JUNE 07	CCB
Q	16098 WAS 18588, ECN 2171	4 DEC 06	AVG
P	SEE SHEET #2 FOR CHANGES, ECN 2126	7 JUL 06	AVG
N	18455 WAS 16954, 9042-0022 WAS 9042-0050 9042-0051 REMOVED, TEST SHEET 18604 WAS CHECKLIST 16365, 9042-0019 WAS QTY X2, ECN 2112	15 MAI 06	AVG
M	9045-0232 WAS 9045-0218, COUPLING 9045-0236 ADDED, ECN 1917	14 NOV 05	AVG
LTR	DESCRIPTION	DATE	CHKD

MATERIAL
SEE INDIVIDUAL PARTS DRAWING

SCALE
AS SHOWN

UNLESS OTHERWISE SPECIFIED
DIMENSIONS ARE IN INCHES

XX ± 0.03
XXX ± 0.01

ANGLES ± 0.5 °
OTHER _____

HOVEY INDUSTRIES 2005 INC

DWN MEP DATE DWN 27 MAR 01

CHKD DATE

DWG SIZE
A1

LTR

USE QA CHECKLIST 18604
 SEE DWG 18455 FOR LABEL PLACEMENT
 SEE DWG 18451 FOR HDW

TITLE	HF 900, 240V BASE BUNG W/COR PLATES	DRAWING NUMBER	REV.
		16356	S SHT. 2/2

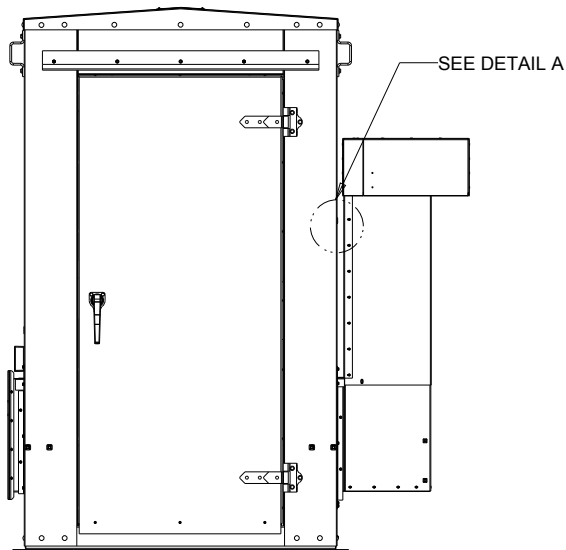

16426-01
 INSTALL AIR TEMP
 SNSR UNDER HOOD
 SEE DETAIL A

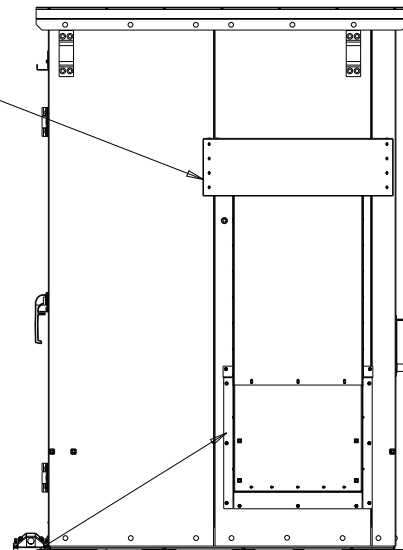

INSTALL GROUND LUG
 9019-0044 & 9019-0043

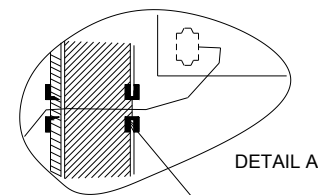

DRILL & INSTALL 9033-0037
 (outside) AND 9019-4004 (inside),
 SILICONE & PASS AMBIENT TEMP
 SENSOR CABLE THROUGH WALL

NOTE: ASSEMBLE PANEL
 16410-03 & -12, 16389 & 1641-13
 AFTER HTR IS IN PLACE

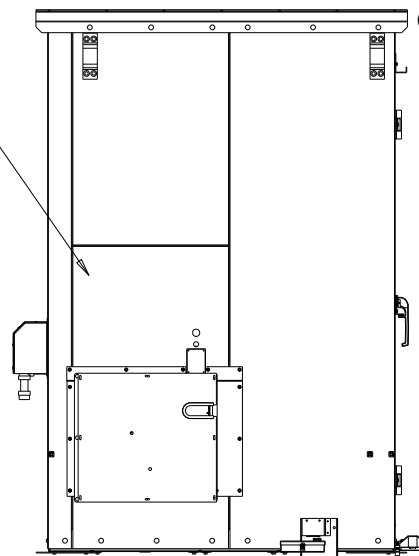

NOT SHOWN
 FOR CLARITY
 12241, 10804, 13341-03, 13393
 18596, 9019-0019
 9033-0043 X 4.5FT, 13036-02

L P S

INSTALL A BEAD OF
 SILICONE 9014-0001 ALL
 AROUND INTAKE AND
 BUNGALOW

FILL EMPTY HOLES
 WITH BOLTS

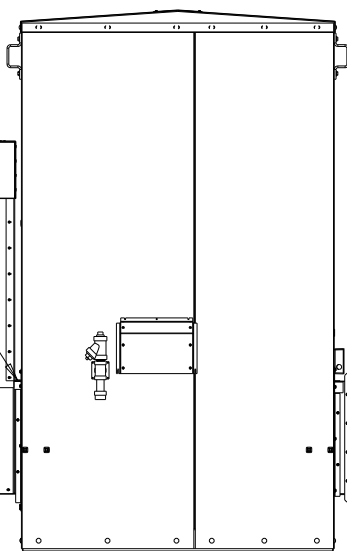

SCALE 0.030

MATERIAL
 SEE INDIVIDUAL PARTS DRAWING

SCALE
 AS SHOWN

UNLESS OTHERWISE SPECIFIED
 DIMENSIONS ARE IN INCHES

XX ± 0.03
 XXX ± 0.01

ANGLES ± 0.5 °
 OTHER _____

HOVEY INDUSTRIES 2005 INC

DWN	DATE DWN	CHKD	DATE
MEP	27 MAR 01		

DWG
 SIZE
 A1

S	13036-02 ADDED, 9019-0033 & 9019-5002 REMOVED FROM "NOT SHOWN FOR CLARITY" BLOCK, ECN 2312, 2322	20 OCT 2008	CCB
R	SEE SHEET # 1 FOR CHANGES, ECN 2212	5 JUNE 07	CCB
Q	SEE SHEET # 1 FOR CHANGES, ECN 2171	4 DEC 06	AVG
P	10804 WAS 12826, ECN 2126	7 JUL 06	AVG
LTR	DESCRIPTION	DATE	CHKD