

INDEX	PART#	DESCRIPTION	QTY
1	9000-5011	ZSCR SD #10-16*.75"L HEX WSHR HD TEKS	6
2	9022-0019-3750	CLAMP, GEAR 3.5"NOM SST	2
3	11142-01	HEATER TUBE, PERFORATED HEX	1
4	15654-01	COLLAR, HEATER TUBE SW RODS	1
5	15829	PLATE SHPPG, HEATER TUBE, SW RODS	1
6	17157-02	SLEEVE, PROTECTIVE EPDM 3.5"ID*24"L	1
7	17168-02	FLEXHOSE, SI 3* 24"L W/O CLAMPS	1



TITLE KIT, HEATING TUBE, SWITCH ROD	DRAWING NUMBER	REV.
	15653	N SHT. 1/2

INCLUDED BUT NOT SHOWN;  
2 PIECES OF STEEL STRAPPING 9022-5002 BY 18" LONG  
INSTALLATION INSTRUCTIONS, 15652

PLACE ALL ANCHOR STRAPS, HARDWARE AND INSTRUCTIONS INSIDE HEATER TUBE.  
INSTALL SHIPPING FLANGE 15829 WITH TIE WRAPS 9011-0001 (X4)

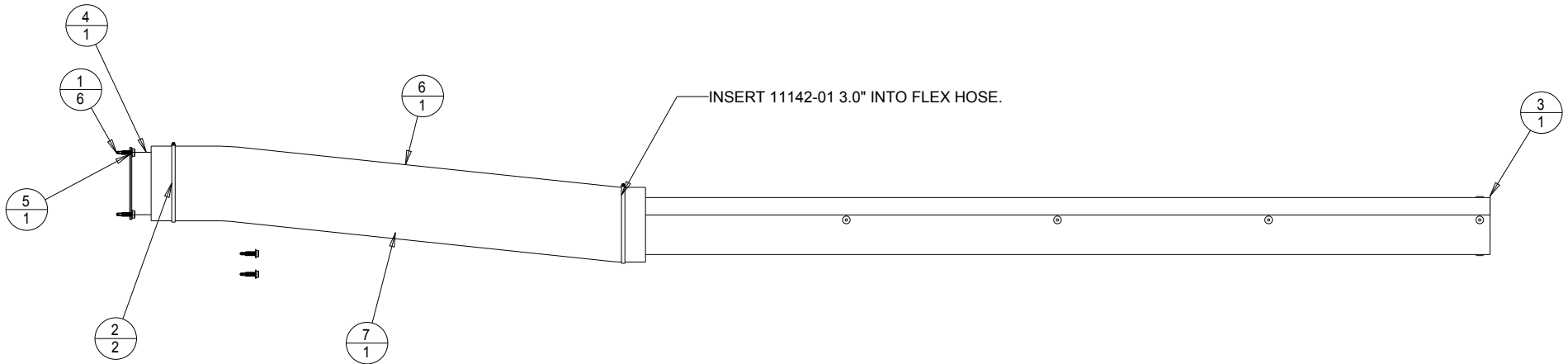

# 15653-01 SINGLE KIT

SCALE  
0.130

MATERIAL	AS SHOWN	SCALE	UNLESS OTHERWISE SPECIFIED DIMENSIONS ARE IN INCHES	XX ± 0.03 XXX ± 0.01	ANGLES ± 0.5 ° OTHER _____	HOVEY INDUSTRIES 2005 INC	DWG SIZE	n	11142-01 WAS 7000-3044. REDRAWN IN PROE. 9000-5011 WAS 9000-5024. ECN 2320.	6OCT2008	GCH
		AS SHOWN				DWN GCH	DATE DWN 6oct2008	CHKD	DATE		CHKD
						A1	REV	DESCRIPTION	DATE		

INDEX	PART#	DESCRIPTION	QTY
1	9000-5011	ZSCR SD #10-16*.75"L HEX WSHR HD TEKS	12
2	9021-0012	FLEXHOSE, SI 3"DIA	1
3	9022-0019-3750	CLAMP, GEAR 3.5"NOM SST	4
4	11142-01	HEATER TUBE, PERFORATED HEX	2
5	15654-01	COLLAR, HEATER TUBE SW RODS	2
6	17157-01	SLEEVE, PROTECTIVE EPDM 3.5"ID*24"L	2

TITLE KIT, HEATING TUBE, SWITCH ROD	DRAWING NUMBER	REV.
	15653	N SHT. 2/2

CUT 48" LONG PIECE OF 9021-0012

INCLUDED BUT NOT SHOWN:  
4 PIECES OF STEEL STRAPPING, 9022-5002 X18" LONG.  
INSTALLATION INSTRUCTION 15652.

SHIP LOOSE. DO NOT ASSEMBLE.

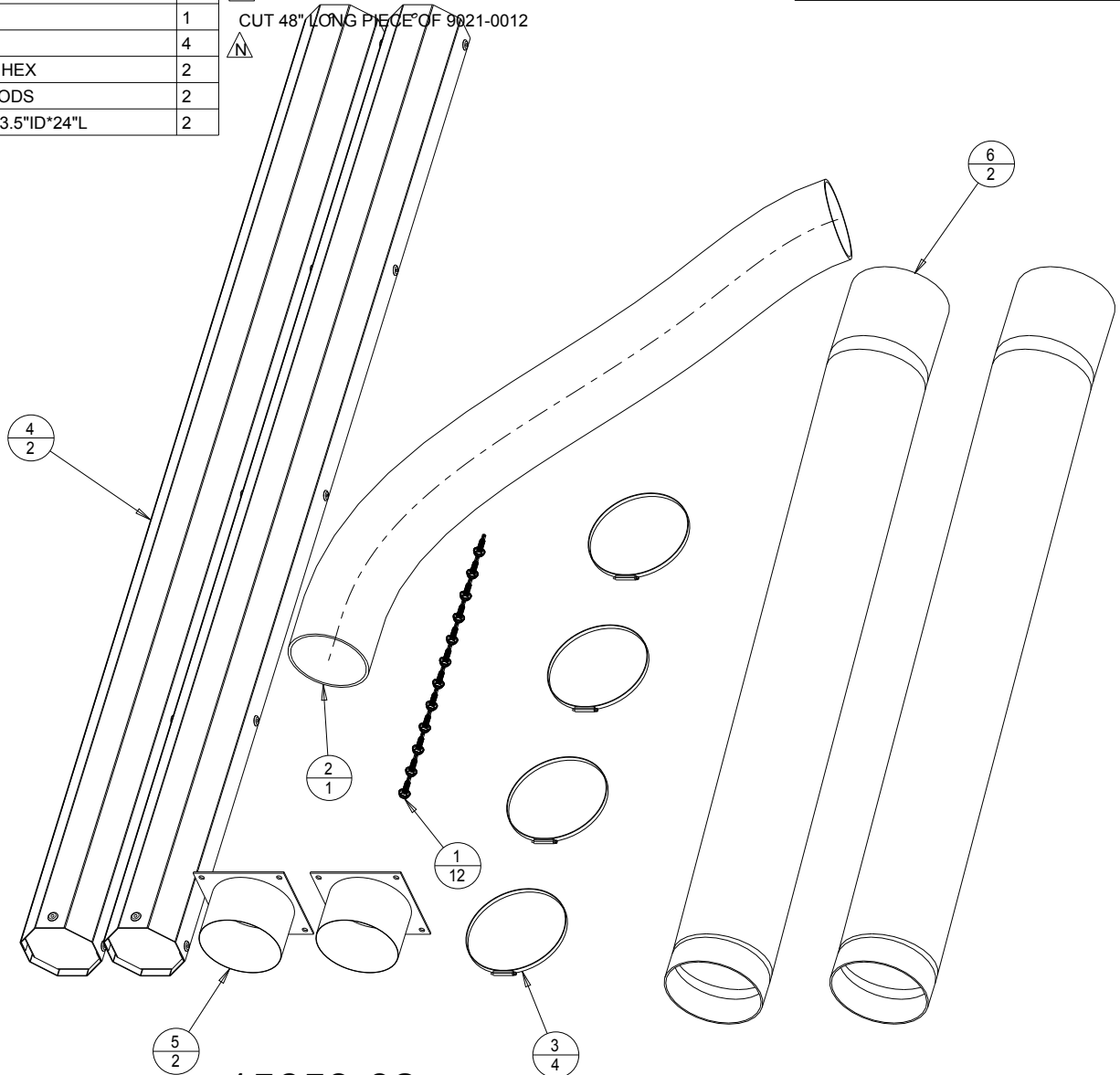

## 15653-02 DOUBLE KIT

MATERIAL	AS SHOWN	SCALE	AS SHOWN	UNLESS OTHERWISE SPECIFIED DIMENSIONS ARE IN INCHES	XX ± 0.03 XXX ± 0.01	ANGLES ± 0.5 ° OTHER _____	HOVEY INDUSTRIES 2005 INC	DWG SIZE	A1	N	11142-01 WAS 7000-3044. REDRAWN IN PROE. 9000-5011 WAS 9000-5024. ECN 2320.	6OCT2008	GCH
							DWN	GCH	DATE DWN	6OCT2008	CHKD	DATE	CHKD
											DESCRIPTION	DATE	